

AMX300 Series DirectConnect™ Mixing Valve

INSTALLATION INSTRUCTIONS

APPLICATION

The AMX300 Series DirectConnect™ Mixing Valves fit any application requiring accurate control of water temperature by mixing hot and cold water such as domestic water. The valves are designed for mounting directly onto the water heater in residences, hotels, schools, hospitals, or nursing homes.

Benefits

The AMX300 valves provide increased comfort and safety for the user, as well as reduced installation time for the plumbing contractor.

Operation

Automatic operation is provided by a thermostatic element. The element will control hot and cold water supply based on valve setting. If cold water is shut off, the valve will reduce the mixed water flow rate in seconds.

The internal parts of the valve are coated with Teflon® to reduce scale build-up for better performance in marginal quality water.

NOTE: Even with the Teflon® coating, the internal parts of the valve may still suffer scale build-up and may require cleaning periodically.

SPECIFICATIONS



CAUTION

Injury Hazard.

Exceeding recommended maximum mix temperature can cause burns.

NOTE: If installing AMX300 Series Valve on a system using PEX, consult PEX tubing manufacturer for maximum allowable temperature ratings.

Maximum Hot Water Inlet Temperature: 212° F (100° C).

Operating cold water inlet temperature range:
33° F to 80° F (.5° C to 27° C).

Operating hot water inlet temperature range:
100° F to 212° F (38° C to 100° C).

Mixed Water Supply temperature range:
100° F to 145° F (38° C to 63° C).

Minimum Required Temperature Difference between Hot and Mix: 27° F (15° C).

Flow Rate:

Minimum - 0.25 gpm (0.95 lpm).
Maximum - See Fig. 7.

Cv at 6 GPM:

2.7 at 100° F (38° C) mixed temperature.
2.1 at 120° F (49° C) mixed temperature.
1.5 at 140° F (60° C) mixed temperature.

Maximum Working Pressure: 150 psi.

Lead Free Plumbing Code Compliance: The wettable surfaces of lead free models contain less than .25% of lead by weighted average

Body Material: Nickel-plated brass/bronze construction, Teflon® coated valve body wear surface, Teflon® coated brass shuttle, EPDM O-rings, and proportional design (simultaneous control of hot and cold ports).

Dimensions: See Fig. 1.



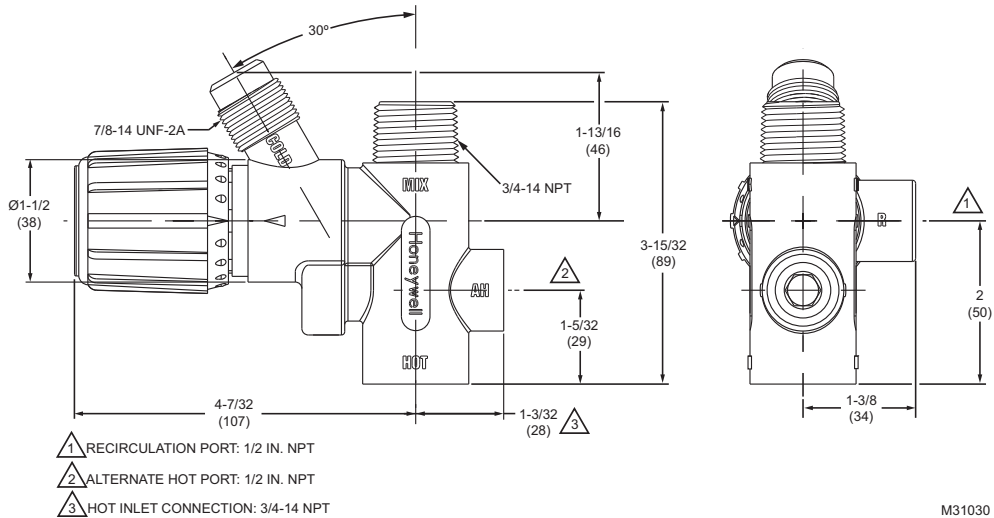

Fig. 1. AMX300 Mixing Valve dimensions in in. (mm).

INSTALLATION

NOTE TO INSTALLER: This product should be installed by a qualified individual, in accordance with local codes and ordinances. It is the responsibility of the installer to properly select, install and adjust these devices as specified in these instructions.

WARNING

Compliance to ASSE 1017 code requires installation of a check valve. An expansion tank must be installed with the check valve to accommodate thermal expansion.

CAUTION

Injury Hazard.
Exceeding recommended maximum mix temperature can cause burns.
Temperature of mixed water from the AMX300 Series DirectConnect Mixing Valve outlet should not exceed 120° F (49° C).

IMPORTANT

1. Do NOT expose the mixing valve to temperatures below 32° F (0° C) or allow it to freeze.
2. Do NOT subject the mixing valve to excess heat during installation.
3. Do NOT use excess thread sealant. If sealant inadvertently enters into the mixing valve chamber, it may cause the internal assembly to malfunction.

1. Before adjusting the outlet mixed water temperature, make sure that the AMX300 Valve is properly installed on the 3/4 in. hot water nipple of the water heater and that the cold water supply to the AMX300 Valve is connected. To be compliant with ASSE 1017 code, a check valve on the cold water side is required.
2. To adjust the outlet mixed water temperature, you must first attach the ThermoStrip (included with the valve) on the outlet pipe connected to the valve. Clean the outlet pipe of the valve first and then firmly apply the ThermoStrip. Flow water and adjust the mixed water outlet temperature to the desired setting range.



Fig. 2. ThermoStrip temperature indicator.

NOTES:

1. The ThermoStrip temperature markers are color-coded for easy reference (See Fig. 2). The actual mixed water temperature is indicated in green with 5° F (3° C) increments. Blue means slightly lower than displayed temperature, and brown means slightly higher than displayed temperature.
2. The thermoStrip is intended for one-time use during initial temperature setting.
3. Open a hot water tap close to the water heater so that mixed water will flow through the AMX300 Valve. The ThermoStrip will show the actual temperature of the mixed water within 10 seconds.
4. To decrease or increase the outlet water temperature, push the mixing valve's handle in towards the valve and turn it clockwise or counterclockwise until the desired temperature is displayed on the ThermoStrip.
5. Ensure that the handwheel is in the locked-out position when finishing the temperature adjustment.

⚠ WARNING

Do not operate the valve at temperatures outside its calibrated range.

Typical Installation Diagrams

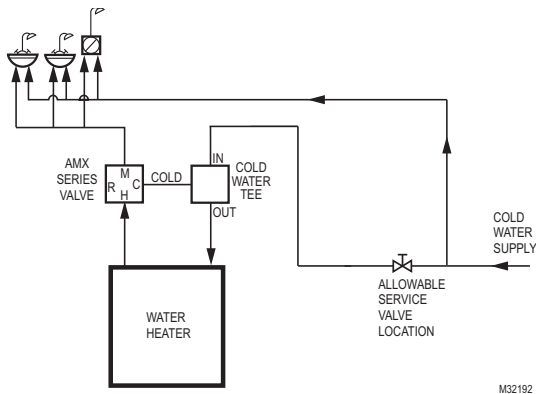

Fig. 3. Basic installation.

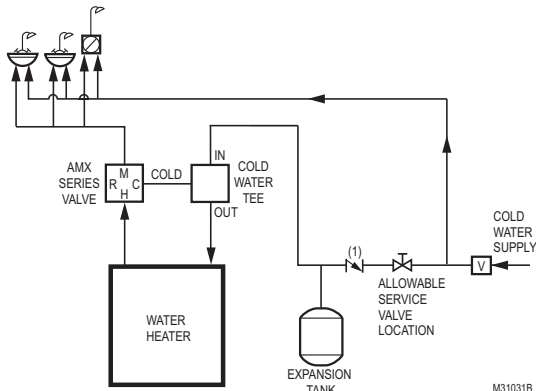

Fig. 4. ASSE 1017 compliant installation without recirculation.

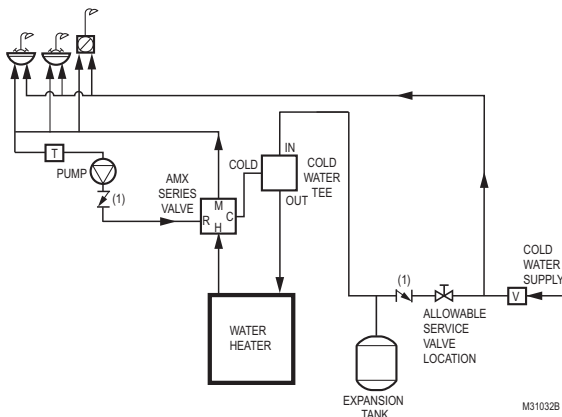

Fig. 5. ASSE 1017 compliant installation with recirculation.

Legend:

1 = Check Valve.

V = Any device that turns the domestic water system into a closed system, such as a backflow preventer, a check valve or a pressure reducing valve.

T = Recirculation pump thermostat control (e.g. Honeywell L6006C1018 Aquastat controller).

NOTE: Installing a device to function as “V” in Figs. 3 and 4 is optional and depends on local codes. If a V type valve is used, it is mandatory that a thermal expansion tank be installed as shown, otherwise, dangerously high pressures could result or the water heater safety relief valve will frequently expel water. If no V device is used, a thermal expansion tank is not required.

NOTE: The recirculation pump must be controlled by a thermostatic controller. If not, a gradual increase in the temperature of the recirculation loop, up to the temperature of the water in the storage tank, can occur.

NOTE: Installing check valve (1) on the cold water supply is required for an ASSE 1017 compliant mixing valve installation. If a check valve is installed, it is mandatory that a thermal expansion tank be installed, as shown.

Recirculation Loop

The purpose of a recirculation loop is to supply immediate tempered water to all hot water fixtures. This helps conserve water. In the recirculation loop, the hot water supply returns from the fixture furthest from the heating source and is connected to the AMX300 Mixing Valve recirculation port (marked "R" on the valve body) and the cold supply line of the water heater.

The AMX300 Mixing Valve allows easy recirculation connection through the integrated recirculation port. A temperature-controlled circulating pump is required to move the tempered water through the recirculation loop. The Honeywell L6006C1018 Aquastat® Controller is the recommended temperature control device for the circulator. The Honeywell Aquastat Controller should be set 5° to 10° F (3° to 5° C) below the controlled mixed water outlet temperature.

⚠ CAUTION

Injury Hazard.

Exceeding recommended maximum outlet mixed water temperature can cause burns.

The AMX300 Series DirectConnect Mixing Valve outlet mixed water temperature should not exceed 120° F (49° C).

VALVE MAINTENANCE

Hard water conditions may result in scale deposits causing binding of internal parts in extreme cases. Cleaning the internal parts will usually restore the valve operating conditions. In some cases, it may be necessary to replace the lower assembly. (See Fig 5.) A Thermostatic Element Replacement Kit, AM-1-025RP, is provided by Honeywell.

AMX300 SERIES DIRECTCONNECT™ MIXING VALVE

To clean or replace the lower assembly, shut off the water supply and:

1. With a screwdriver, remove the screw and the handwheel.
2. Unscrew the lower nut (turn it counterclockwise) to remove the top assembly. The brass top assembly will pop up.
3. Remove the lower assembly, diffuser, and spring.

⚠ WARNING

Do not use solvents or scratch the metallic or Teflon® coated surfaces.

4. Carefully remove any scaling (calcium deposits) or foreign particles from the valve seat and other internal parts. Use vinegar to remove the calcium deposits. Soak parts until the calcium deposits become soft enough to be scrubbed and washed off.

5. Replace the clean spring, diffuser and lower assembly following the instructions below or use a new replacement kit assembly.
 - a. Insert the spring into the diffuser.
 - b. Insert the diffuser with the spring end first into the body.
 - c. Fit the valve top assembly into the lower assembly and insert into the valve.
 - d. Tighten the lower nut.
 - e. Tighten the upper nut.
6. Place the handwheel on the valve.
7. Screw the handwheel onto the valve.
8. Push down and turn the handwheel to set the desired temperature.

NOTE: Additional thermostrips are available from Honeywell in packs of 10 (TS205-064).

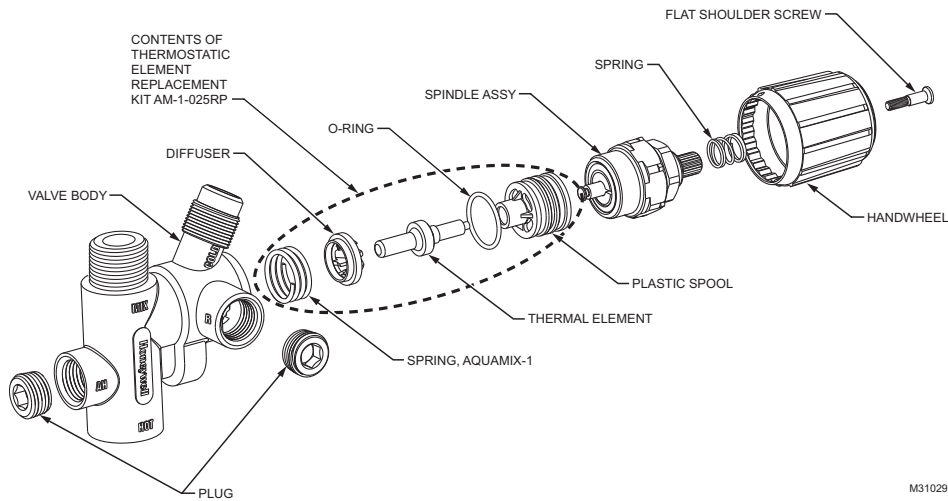

Fig. 6. Expanded view of the AMX300 Series Mixing Valve.

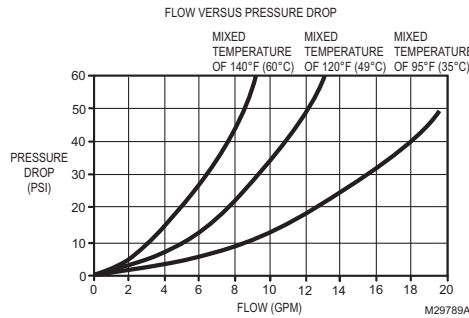

Fig. 7. Pressure Drop Chart

Allen® is a registered trademark of Industrial Fasteners, Inc.
 Teflon® is a registered trademark of E I duPont de Nemours and Company

Automation and Control Solutions

Honeywell International Inc.
 1985 Douglas Drive North
 Golden Valley, MN 55422

Honeywell Limited-Honeywell Limitée
 35 Dynamic Drive
 Toronto, Ontario M1V 4Z9
 customer.honeywell.com



© U.S. Registered Trademark
 © 2010 Honeywell International Inc.
 62-3112—08 M.S. Rev. 10-10
 Printed in U.S.A.